

**Airclos**<sup>®</sup>  
Aluminium Systems

**Retractable and  
fixed roofs.**

**Unique  
architectural glass  
solutions.**



## TABLE

<b>Airclos - Aluminium systems .....</b>	<b>4</b>
Airclos T6000 .....	6
Airclos T6000 V .....	8
Airclos T8000 .....	10
Airclos T8003 .....	12
Airclos T8000 ER .....	14
Airclos T6000 F .....	<b>16</b>
<b>Thermal break and energy efficiency .....</b>	<b>18</b>
Airclos T7000 RPT .....	20
Airclos F105 RPT .....	<b>22</b>
<b>The RDI process .....</b>	<b>24</b>
<b>Custom development and structure calculation .....</b>	<b>26</b>
<b>Advantages of Airclos' fixed and retractable roofs .....</b>	<b>52</b>
<b>Automation. Your home or business, always connected.....</b>	<b>54</b>
<b>Glazing options .....</b>	<b>56</b>
<b>Property comparison between series .....</b>	<b>58</b>
<b>Other Airclos products .....</b>	<b>60</b>



T6000 - Retractable Roof  
Opium, Dublin, Ireland.

## Airclos - Aluminium systems.

Airclos has more than 35 years of experience in the manufacture of enclosure systems and sun protection.

At our production centre in Spain we develop, manufacture, and distribute a wide range of products for projects around the world.

### How we do it.

The quality of our service is based on four fundamental pillars.

#### 1. We adapt the system to your project.

Work in direct collaboration with our team of technicians, made up of highly qualified personnel. This team studies and designs the best custom solution for each project individually and exclusively.

#### 2. Measuring and analysis of the space.

In technically demanding projects, the correct measurement and analysis of the installation

For this reason, we advise our customers regarding on-site measurements and make the necessary modifications to the design according to the characteristics of the installation site.

#### 3. We train, support and supervise on site.

Our installers are trained to install these systems, and our on-site support and supervision services guarantee their proper installation.

#### 4. Our own guarantee and after-sales service.

Offering a good product also depends on an efficient, flexible and safe after-sales service.

To achieve this, Airclos only manufactures systems developed in-house, including fittings and accessories, in order to guarantee immediate after-sales service for the entire useful life of the product.

## AIRCLOS IN FIGURES



PROJECTS IN

**+37** countries



IN-HOUSE DESIGN FOR

**+26** systems



EXPERIENCE OF

**+37** years

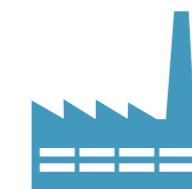

MANUFACTURING CENTRE OF

**+3000** m<sup>2</sup>



TEAM OF

**+25** experts



**T6000 - Retractable Roof**  
The Sinclairs Hotel, Fort Worth, USA

**Airclos T6000** - Up to 11.2-m projection, and glass panels up to 2.2-m wide.

## Details Airclos T6000 Technical Data Sheet

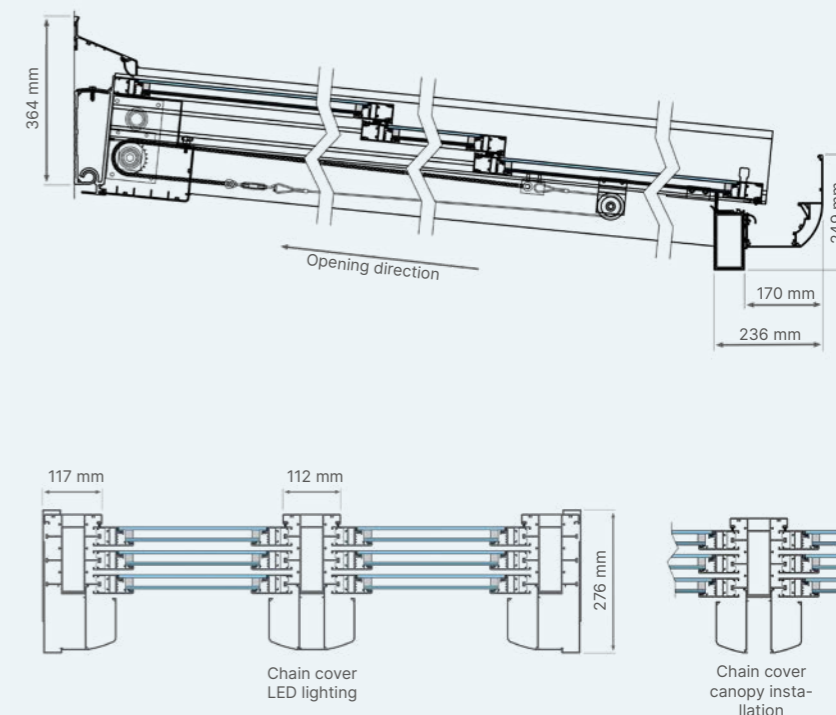

The T6000 series is the most versatile series of our range of motorised retractable roofs.

It is specially designed to cover large spaces, offering excellent tightness and insulation.

### Great entry of natural light.

This series maximises the entry of light in any room, reducing the necessary structure to the minimum.

The unique design of the T6000 retractable roof allows up to 11.2-m projection (22.4 m in the case of double slope) and glass panels up to 2.2-m wide.

The motorised roof panels of the T6000 series slide automatically to open up to 87% of the enclosure.

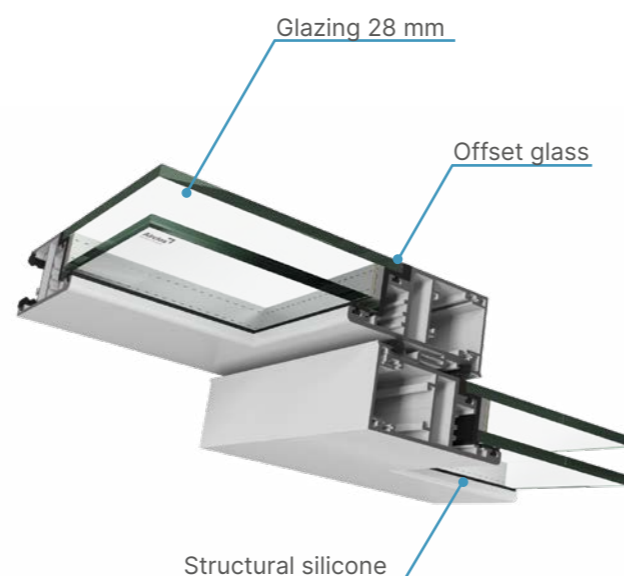

### Glass and panels.

Glass and panels can be chosen according to the needs of each project. All the information about the different types of glass can be found in the 'Glazing options' section.

The T6000 series can be fitted with single or air space glass, or with polycarbonate or aluminium panel.

### Thermal transmittance.

3.0 W/m<sup>2</sup>K\* With a glass, Ug value = 1.0 W/m<sup>2</sup>K

\* According to UNE-EN ISO 10077-1:2020. Thermal performance of windows, doors and shutters. Calculation of thermal transmittance. Part 1: General aspects (ISO 10077-1:2017, corrected version 2020-02).

<b>Material</b>	Aluminium
<b>Profile finishes</b>	RAL · Anodised · Wood
<b>System</b>	Retractable, motorised
<b>Multi-channel control</b>	Yes
<b>Max. panel width with glass</b>	2,200 mm
<b>Max. panel width with sandwich panel</b>	2,300 mm
<b>Max. polycarbonate panel width</b>	2,300 mm
<b>Max. projection without intermediary pillars</b>	8,500 mm
<b>Opening</b>	66, 75, 80, 83, 86, 87%
<b>Slope</b>	Standard: 10% 8% - 100% (45°)
<b>Number of panels per module</b>	2 - 8
<b>Uw-value</b>	3.0 W/m <sup>2</sup> K
<b>Laminated glass</b>	4+4 mm
<b>Insulating glass</b>	28 mm
<b>Polycarbonate</b>	16, 20, 25 mm
<b>Aluminium panel</b>	16, 20, 25 mm

Details Airclos T6000V  
Technical Data Sheet



T6000V - Retractable Roof  
Private home, Castellón, Spain

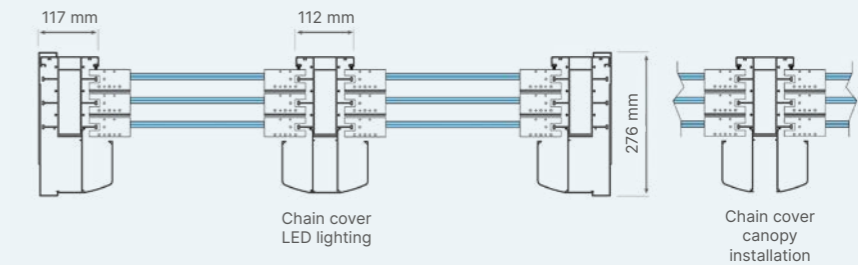
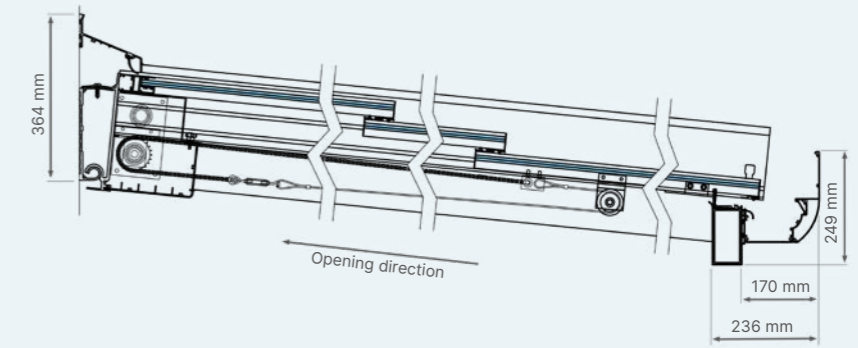

**Airclos T6000 V** - Maximum transparency, no horizontal profiles to obstruct vision.

The T6000 V is the most striking choice of our range of motorised retractable roofs, making it the perfect option when looking for maximum transparency.

This panoramic view effect is achieved thanks to its panels with no horizontal profiles.

In order to guarantee the safety and stiffness of the system, 12 mm thick laminated and laminated-tempered glass is used, enabling the installation of glass panels up to 1.5 m wide.

Its transparent gasket system air tightens the system without hindering the view.

**Total transparency.**

Glass panels with no horizontal profiles to obstruct the view and transparent gaskets for incredible panoramic views.

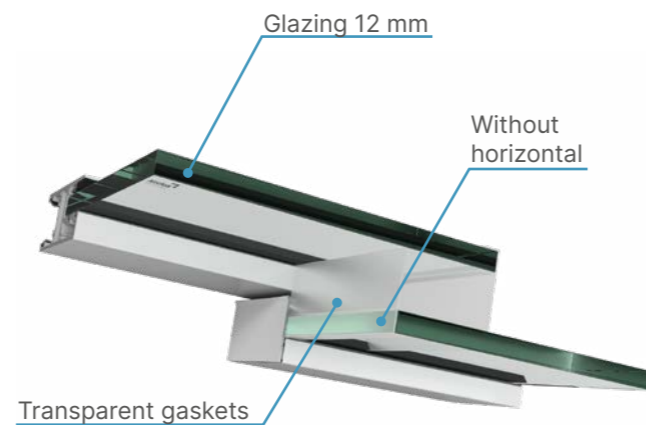

**Glass.**

Glass and panels can be chosen according to the needs of each project.

All the information about the different types of glass can be found in the 'Glazing options' section.

The T6000V series can be fitted with single glazing.

<b>Material</b>	Aluminium
<b>Profile finishes</b>	RAL · Anodised · Wood
<b>System</b>	Retractable, motorised
<b>Multi-channel control</b>	Yes
<b>Max. panel width with glass</b>	1,500 mm
<b>Max. panel width with sandwich panel</b>	-
<b>Max. polycarbonate panel width</b>	-
<b>Max. projection without intermediary pillars</b>	8,500 mm
<b>Opening</b>	66, 75, 80, 83, 86, 87%
<b>Slope</b>	Standard: 10% 8% - 100% (45°)
<b>Number of panels per module</b>	2 - 8
<b>Uw-value</b>	6.05 W/m²K
<b>Laminated glass</b>	6+6 / 6+6T
<b>Insulating glass</b>	-
<b>Polycarbonate</b>	-
<b>Aluminium panel</b>	-



T8000 - Retractable Roof  
Private home, Zarautz, Spain

## Airclos T8000 - Large motorised enclosures with spans up to 3.6 m wide.

## Details Airclos T8000 Technical Data Sheet

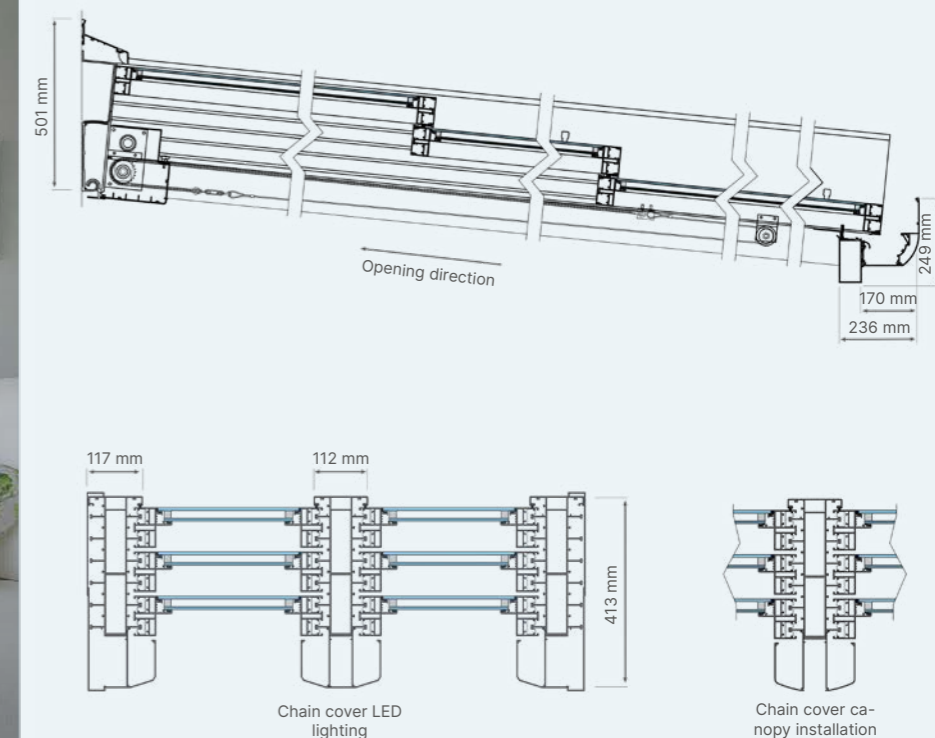

The T8000 series is the most robust in our range of retractable roofs.

It is specially designed to cover large spaces with minimum visual obstacles and excellent tightness and insulation.

### Great reinforcement for larger sashes.

The extra reinforcement with which the profiles of the T8000 series retractable enclosures have been designed makes it possible to create larger sashes with fewer panels.

Thanks to this unique design, it is possible to install glass panels up to 3.6 m wide.

Besides, the extra weight of the panels does not affect the projection of the roof. Its unique development makes it possible to manufacture systems with up to 6.5 m of projection without intermediary pillars, and with up to 7.8 m of projection when installed on a structure (15.6 m in the case of double slope).

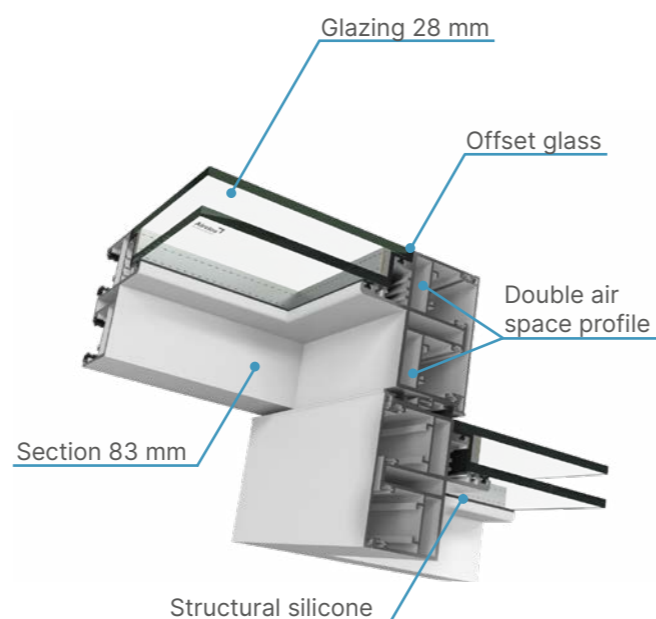

### Double air space profile.

The double air space profile facilitates the fitting of a support bracket and double the number of skid blocks, thus reinforcing the profile and improving traction.

### Glass.

Glass and panels can be chosen according to the needs of each project.

All the information about the different types of glass can be found in the 'Glazing options' section.

The T8000 series can be fitted with insulating glass.

<b>Material</b>	Aluminium
<b>Profile finishes</b>	RAL · Anodised · Wood
<b>System</b>	Retractable, motorised
<b>Multi-channel control</b>	Yes
<b>Max. panel width with glass</b>	3600 mm
<b>Max. panel width with sandwich panel</b>	-
<b>Max. polycarbonate panel width</b>	-
<b>Max. projection without intermediary pillars</b>	6500 mm
<b>Opening</b>	66, 75, 80%
<b>Slope</b>	Standard: 10% 8% - 100% (45°)
<b>Number of panels per module</b>	3 - 5
<b>Uw-value</b>	2.76 W/m <sup>2</sup> K
<b>Laminated glass</b>	-
<b>Insulating glass</b>	28 mm
<b>Polycarbonate</b>	-
<b>Aluminium panel</b>	-

## Details Airclos T8003 Technical Data Sheet

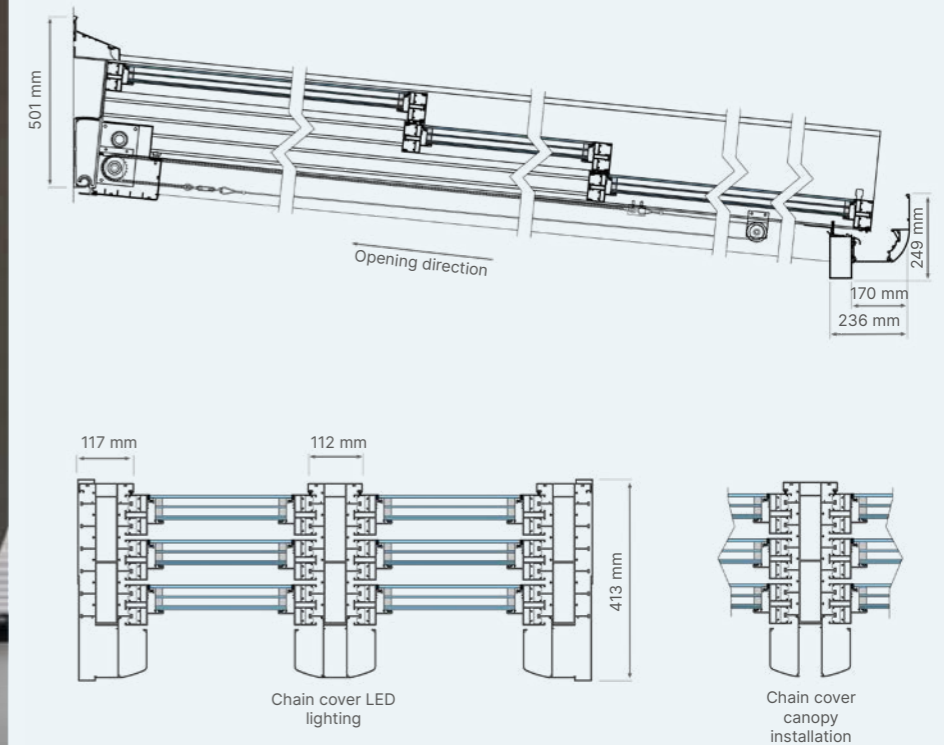

**T8000 - Retractable Roof**  
Julia's Park Residential complex, The Hague, The Netherlands

### Airclos T8003 - Large motorised enclosures with glass with Ug-value = 0.5 W/m²K.

The T8003 series with triple glazing is the most thermally and acoustically insulated retractable roof series within our product range.

#### Triple glazing with Ug-value = 0.5 W/m²K.

The triple glazing of this roof is specially designed to reduce its Ug-value.

The special composition of the glass used in this series offers an unbeatable Ug-value of 0.5 W/m²K.

Besides, the extra reinforcement with which the profiles of the T8003 series retractable enclosures have been designed makes it possible to create larger sashes with fewer panels.

Thanks to this unique design, it is possible to install glass panels up to 3.6 m wide.

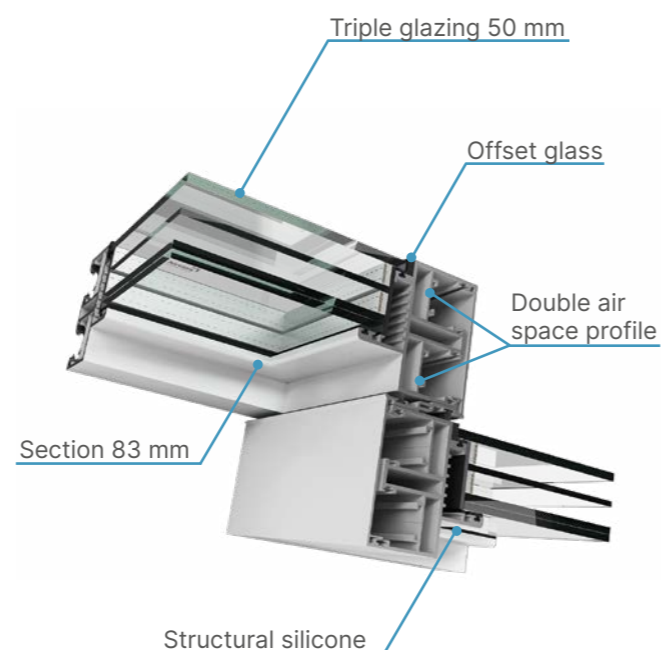

#### Double air space profile.

The double air space profile facilitates the fitting of a support bracket and double the number of skid blocks, thus reinforcing the profile and improving traction.

#### Thermal transmittance.

2.4 W/m²K\* With a glass, Ug value = 0.5 W/m²K

\* According to UNE-EN ISO 10077-1:2020. Thermal performance of windows, doors and shutters. Calculation of thermal transmittance. Part 1: General aspects (ISO 10077-1:2017, corrected version 2020-02).

<b>Material</b>	Aluminium
<b>Profile finishes</b>	RAL · Anodised · Wood
<b>System</b>	Retractable, motorised
<b>Multi-channel control</b>	Yes
<b>Max. panel width with glass</b>	3600 mm
<b>Max. panel width with sandwich panel</b>	-
<b>Max. polycarbonate panel width</b>	-
<b>Max. projection without intermediary pillars</b>	6500 mm
<b>Opening</b>	66, 75, 80%
<b>Slope</b>	Standard: 10% 8% - 100% (45°)
<b>Number of panels per module</b>	3 - 5
<b>Uw-value</b>	2.4 W/m²K
<b>Laminated glass</b>	-
<b>Triple glazing</b>	50 mm
<b>Polycarbonate</b>	-
<b>Aluminium panel</b>	-



**T6000 - Retractable Roof**  
Private home, Bjørnemyr, Norway

## Details Airclos T8000 ER Technical Data Sheet

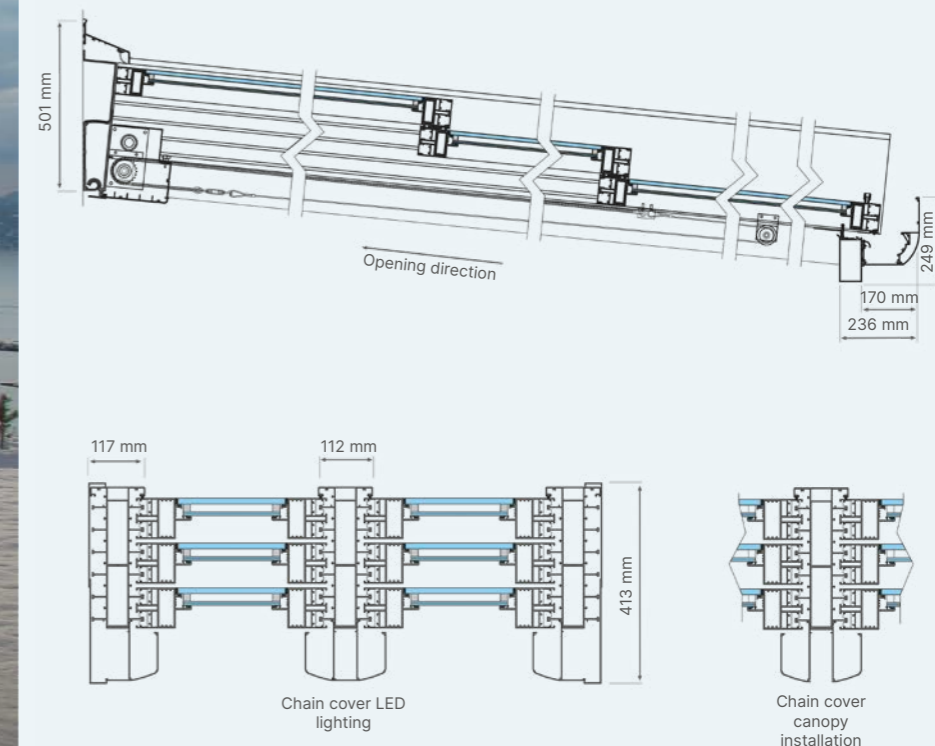

### Airclos T8000 ER - Special system for snow loads up to 700 kg/m<sup>2</sup>.

The T8000 ER series has been specifically designed for an unprecedented load capacity. It features a new, carefully designed panel profile, tempered insulating glass up to 12-mm thick (per element) and specially reinforced rails.

#### Special reinforcement for snow loads up to 700 kg/m<sup>2</sup>.

The perfect solution for areas that experience highland and/or extreme climates (such as the Swiss Alps or Scandinavia), where in some cases snow loads of up to 700 kg/m<sup>2</sup> can be reached. Conventional retractable roof solutions are not suitable for such high-load values.

In comparison, it can be stated that the panels of the new T8000 ER series are twice as strong as the conventional T8000-series panels, and the reinforced version is up to 4 times better.

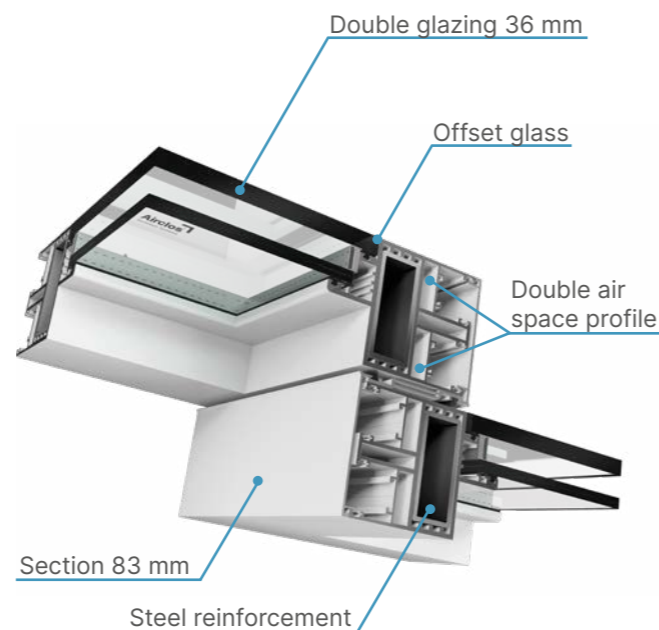

#### Glass panels up to 4-m wide.

In addition, the new T8000 ER is not only suitable for areas experiencing extreme climate.

In more favourable situations, it can cover larger widths with the least amount of intermediate profiles. Thanks to this unique design, glass panels up to 4-m wide can be installed.

#### Comparison of resistance.

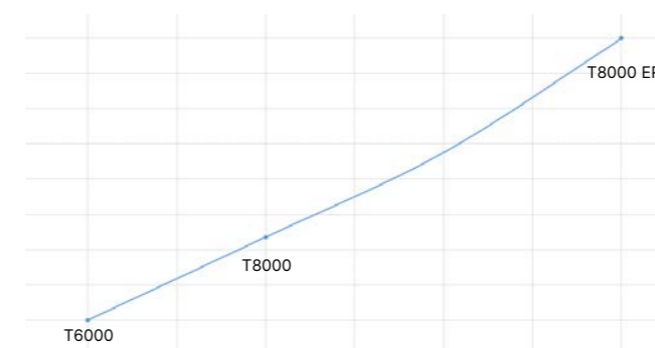

<b>Material</b>	Aluminium
<b>Profile finishes</b>	RAL · Anodised · Wood
<b>System</b>	Retractable, motorised
<b>Multi-channel control</b>	Yes
<b>Max. panel width with glass</b>	4000 mm
<b>Max. panel width with sandwich panel</b>	-
<b>Max. polycarbonate panel width</b>	-
<b>Max. projection without intermediary pillars</b>	6500 mm
<b>Opening</b>	50, 66, 75, 80, 83%
<b>Slope</b>	Standard: 10% 8% - 100% (45°)
<b>Number of panels per module</b>	2 - 6
<b>Uw-value</b>	2.8 W/m <sup>2</sup> K
<b>Laminated glass</b>	-
<b>Double glazing</b>	36 mm
<b>Polycarbonate</b>	-
<b>Aluminium panel</b>	-

## Details Airclos T6000 F Technical Data Sheet



T6000 F - Fixed Roof  
Private home, Girona, Spain

**Airclos T6000 F** - Up to 11.2-m projection, and glass panels up to 2.2-m wide.

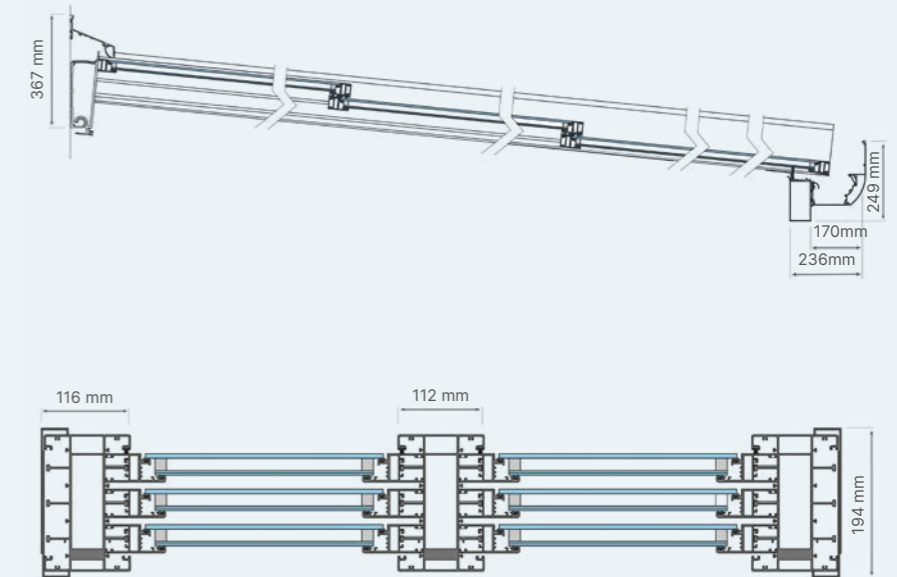

The T6000 F series is the most versatile of our fixed roof range.

It is specially designed to cover large spaces, offering excellent tightness and insulation.

### Great entry of natural light.

This series maximises the entry of light in any room, reducing the necessary structure to the minimum.

The unique design of the T6000 F fixed roof allows up to 11.2-m projection (22.4 m in the case of double slope) and glass panels up to 2.2-m wide.

### Quick installation.

This system's main benefit is its quick and easy installation. It is supplied with the rails and the fixing supports, the panels fully assembled, and the rest of the profiles cut to size, ready to mount on site.



### Glass and panels.

Glass and panels can be chosen according to the needs of each project.

All the information about the different types of glass can be found in the 'Glazing options' section.

The T6000 F series can be fitted with single or air space glass, or with polycarbonate or aluminium panel.

### Thermal transmittance.

3.0 W/m<sup>2</sup>K\* With a glass, Ug value = 1.0 W/m<sup>2</sup>K

\* According to UNE-EN ISO 10077-1:2020. Thermal performance of windows, doors and shutters. Calculation of thermal transmittance. Part 1: General aspects (ISO 10077-1:2017, corrected version 2020-02).

Material	Aluminium
Profile finishes	RAL · Anodised · Wood
System	Fixed
Max. panel width with glass	2,200 mm
Max. panel width with sandwich panel	2,300 mm
Max. polycarbonate panel width	2,300 mm
Max. projection without intermediary pillars	8,500 mm
Opening	66, 75, 80, 83, 86, 87%
Slope	Standard: 10% 8% - 100% (45°)
Number of panels per module	2 - 8
Uw-value	3.0 W/m <sup>2</sup> K
Laminated glass	4+4 mm
Insulating glass	28 mm
Polycarbonate	16, 20, 25 mm
Aluminium panel	16, 20, 25 mm



T6000 - Retractable Roof  
The Sinclairs Hotel, Fort Worth, USA

## Thermal break (TB) and energy efficiency.

### Transmittance.

Transmittance (also known as U-value) expresses the amount of energy that passes through a body per unit of time.

In the International System it is measured in  $W/m^2K$  or  $W/m^2°C$  units. The lower this value, the lower the transmittance and therefore the higher the thermal performance of the material.

### The thermal break (TB).

A thermal break occurs when a specific element (the frame of a window, for example) has a higher U-value transmittance than the adjoining elements (the walls).

This situation makes heat, which is always looking for the easiest escape route, to exit through these elements, thus reducing the comfort of the room.

This phenomenon is especially intensified when working with highly-conductive materials such

as aluminium.

Thermal break was created precisely to reduce this temperature transmission. To achieve this, the different sides of the conductive material should not come into contact with each other, so a very low-conductive material is inserted between them (usually polyamide).

### Thermal break and energy efficiency.

As mentioned in the previous paragraphs, the lower the insulation of a house, the higher the temperature that is transmitted between the inside and the outside.

These losses increase the demands on air-conditioning systems, negatively affecting our energy consumption.

### Airclos roofs and thermal break.

Achieving maximum comfort when designing spaces has always been a maxim for professionals in our industry.

Airclos goes a step further and aims at offering a range of products that are highly optimised to reduce energy consumption and environmental impact.

Our retractable and fixed roof systems with thermal break are revolutionary in this sense,

especially the T7000 RPT series, the first motorised retractable roof series on the market with true thermal break.

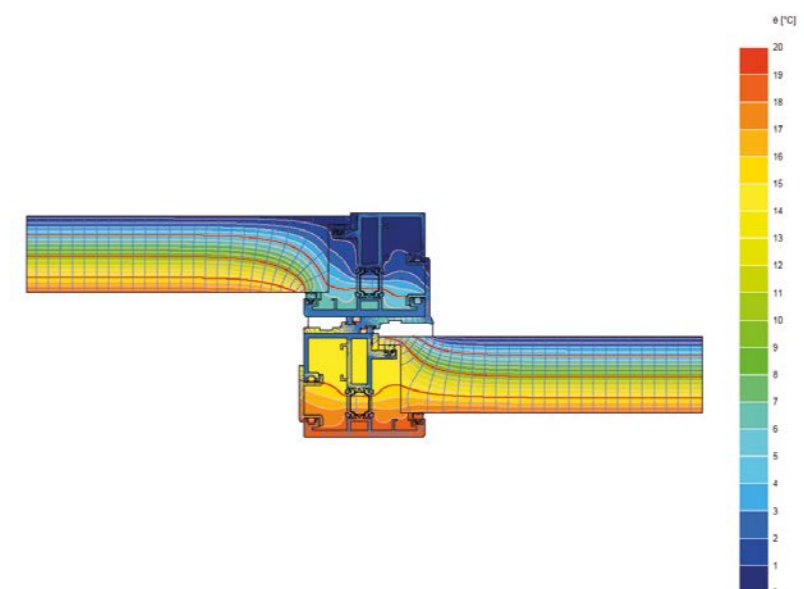



**T8000 - Retractable Roof**  
Julia's Park Residential complex, The Hague, The Netherlands

## Details Airclos T7000 RPT Technical Data

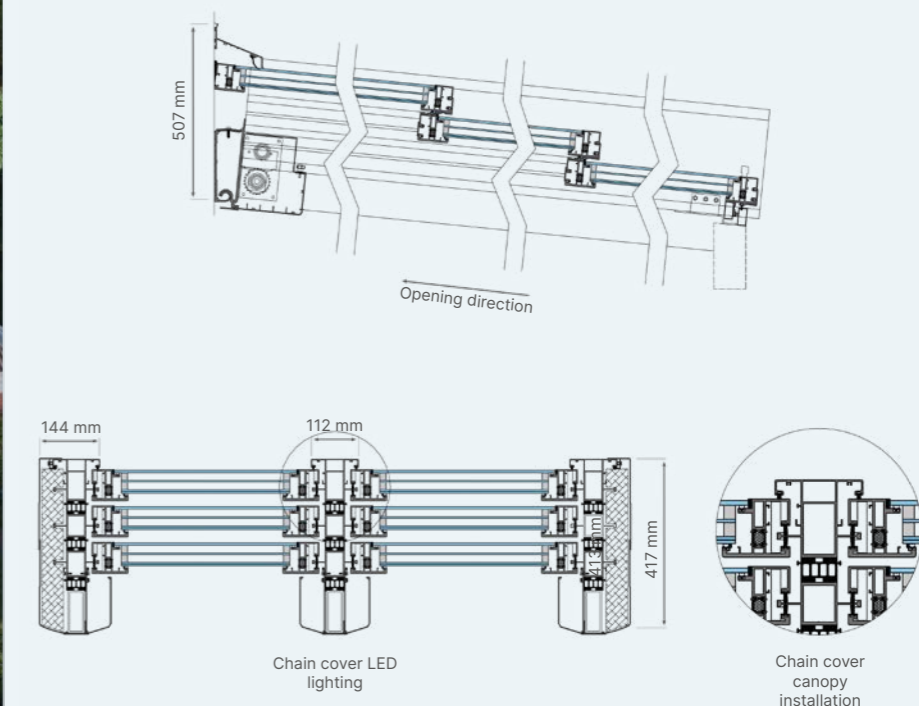

### Airclos T7000 RPT - True Thermal Break for a U-value = 1.4 W/m<sup>2</sup>K.

The T7000 RPT series is the first retractable roof series on the market equipped with true Thermal Break and triple glazing for unprecedented thermal performance.

#### True Thermal Break for a U-value = 1.4 W/m<sup>2</sup>K.

To achieve this, a longitudinal TB is created to cover all the points of contact between the indoor and outdoor profile.

- **Addition of polyamide on the inside of panel profiles:** to avoid contact between the inner and outer sides of the panels.
- **Polyurethane (PUR) Foam filling in panel profiles:** the polyamide inside the profiles forms a gap which is filled with Polyurethane Foam.
- **Addition of polyamide where the panels overlap:** as panels overlap in this system, polyamide is added on the outer side of the panels to avoid direct contact.
- **Addition of polyamide between the**

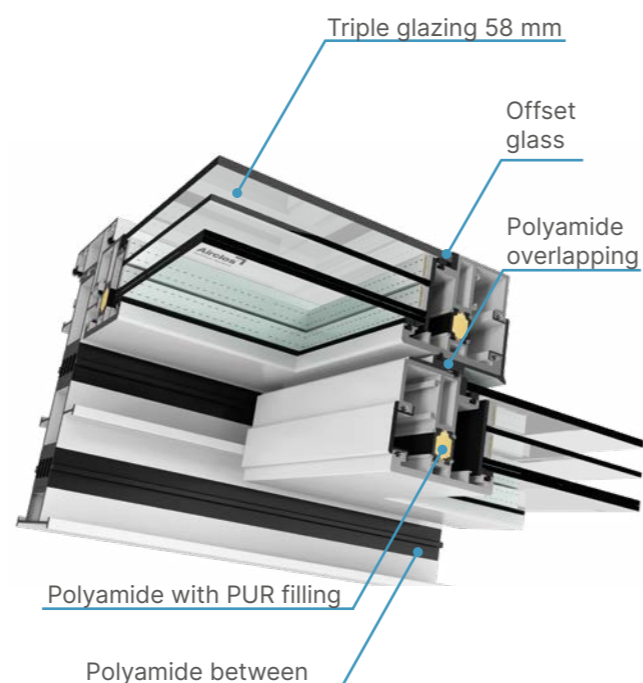

**rails:** as in the previous case, as it is an overlapping system, polyamide profiles are also included between the aluminium rails.

#### Triple glazing with Ug value = 0.5 W/m<sup>2</sup>K.

The triple glazing is specially designed to reduce its transmittance, reaching an unbeatable Ug-value of 0.5 W/m<sup>2</sup>K.

The triple glazing is made of a 4 + 4 mm low-emissivity laminated glass on the inside, 18-mm argon space, 4-mm tempered intermediary glass, 18-mm argon space, and 6-mm tempered low-emissivity glass and sun protection on the outside.

#### Thermal transmittance.

1.4 W/m<sup>2</sup>K\*      With a glass, Ug value = 0.5 W/m<sup>2</sup>K

\* According to UNE-EN ISO 10077-1:2020. Thermal performance of windows, doors and shutters. Calculation of thermal transmittance. Part 1: General aspects (ISO 10077-1:2017, corrected version 2020-02).

<b>Material</b>	Aluminium
<b>Profile finishes</b>	RAL · Anodised · Wood
<b>System</b>	Retractable, motorised
<b>Multi-channel control</b>	Yes
<b>Max. panel width with glass</b>	2,200 mm
<b>Max. panel width with sandwich panel</b>	-
<b>Max. polycarbonate panel width</b>	-
<b>Max. projection without intermediary pillars</b>	6,500 mm
<b>Opening</b>	66, 75, 80%
<b>Slope</b>	Standard: 10% 8% - 100% (45°)
<b>Number of panels per module</b>	3 - 5
<b>Uw-value</b>	1.4 W/m <sup>2</sup> K
<b>Laminated glass</b>	-
<b>Triple glazing</b>	58 mm
<b>Polycarbonate</b>	-
<b>Aluminium panel</b>	-

## Details Airclos F105 Technical Data Sheet



**F105 RPT - Fixed Roof**  
Private home, Toledo, Spain

**Airclos F105 RPT** - Fully watertight, highly resistant glass roof.

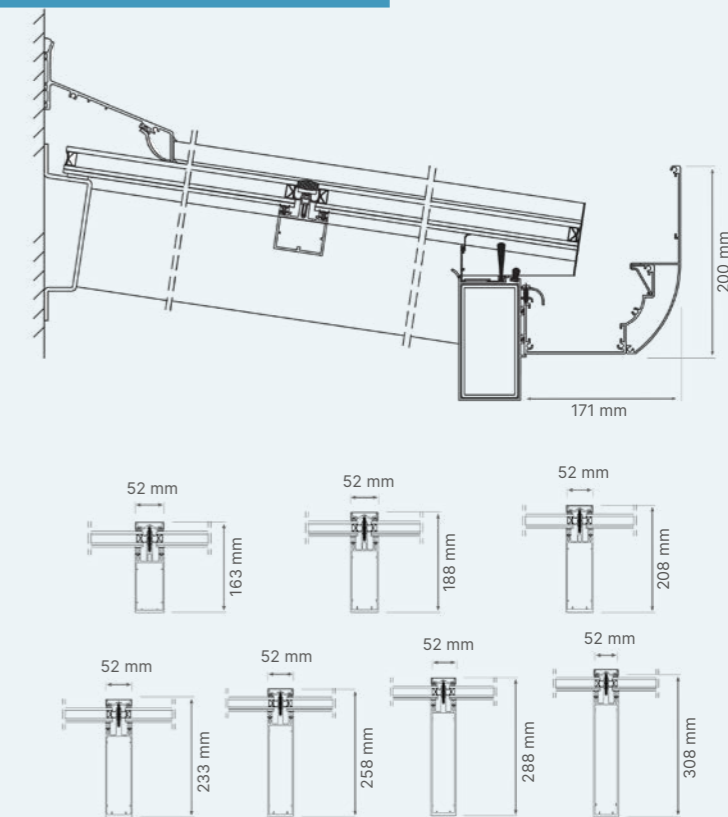

The F105 series is the option with Thermal Break within the Airclos fixed roof range.

It is a fixed glass roof that provides great thermal insulation and a considerable amount of light.

### Thermal break and great transparency.

It stands out especially for being a roofing system with TB, which offers great thermal and acoustic insulation, making the system greatly resistant to atmospheric corrosion.

As it is a glass roof which includes a minimum number of profiles within its structure, transparency is one of its great advantages.

### Custom structures.

As detailed in the technical data sheet above, there are different stud and structure options available depending on the needs of each project.



Structure calculation is essential for this type of system. Different aspects are taken into account depending on the load to be supported: roof projection, glass weight, climatic zone (snow and wind loads...), etc.

These structures may also be reinforced on the inside if necessary.

### Thermal transmittance.

1.2 W/m<sup>2</sup>K\*      With a glass, Ug value = 1.0 W/m<sup>2</sup>K

\* According to UNE-EN ISO 10077-1:2020. Thermal performance of windows, doors and shutters. Calculation of thermal transmittance. Part 1: General aspects (ISO 10077-1:2017, corrected version 2020-02).

<b>Material</b>	Aluminium
<b>Profile finishes</b>	RAL · Anodised · Wood
<b>System</b>	Fixed
<b>Maximum panel width with glass</b>	900 mm
<b>Maximum panel width with sandwich panel</b>	-
<b>Maximum polycarbonate panel width</b>	-
<b>Maximum projection without intermediary pillars</b>	7,000 mm
<b>Slope</b>	Standard: 10% 8% - 100% (45°)
<b>Uw-value</b>	1.2 W/m <sup>2</sup> K
<b>Laminated glass</b>	-
<b>Insulating glass</b>	28 mm
<b>Polycarbonate</b>	-
<b>Aluminium panel</b>	-



T6000 - Retractable Roof + E20 - Sliding glass wall  
Lazy Pig In The Pantry, Chesham, United Kingdom

## The RDI process

### In-house design systems.

All profiles and fittings used in our systems have been designed and patented by Airclos.

We have a large technical team that works around the clock to improve existing systems and develop new solutions.

### RDI lines.

- New market needs:**

User needs change and the market evolves, thus generating new demands.

Improved thermal performance, larger spans or fewer intermediate structures are just some of the latest innovations introduced in response to the demands of our public.

Detecting these new needs and trends and developing custom solutions are just some of our main objectives.

- Innovative solutions:**

Our products are entirely manufactured by Airclos.

Positioning ourselves as a leader in new product innovation and design is another key driver of our research.

Not only do we use the latest technology, but we also create new technology to provide increasingly innovative solutions.

- Efficient architecture and sustainability:**

Creating more environmentally friendly products is of paramount importance to us.

In addition, these advances are aimed at making buildings increasingly more efficient and therefore more sustainable.

## RDI LINES

### NEW MARKET NEEDS



### INNOVATIVE SOLUTIONS

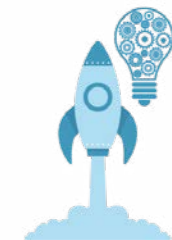

### EFFICIENT ARCHITECTURE AND SUSTAINABILITY



T6000 - Retractable Roof  
Hôtel Môm'Art, Paris, France

## Custom development and structure calculation.

### We adapt the system to your project.

Our team of technicians, made up of highly qualified personnel, studies and designs the best solution for each project in a unique and exclusive way.

When a customer contacts Airclos, the sales team proposes the most suitable solutions for each project.

These proposals are designed together with the technical team in order to guarantee the quality, reliability and performance of the products to be offered.

### In search of the best solution:

Airclos' roof range, whether retractable or fixed, is carefully designed since, given their role, they are critical elements in any malfunction situation.

Overall, their performance depends mainly on the following factors:

- **Weight:** the use of glass places a significant load on the structural elements that make up the roof.
- **Weather impact:** wind and snow loads that the roof or enclosure must withstand during its useful life without being damaged in any way.
- **Geometry:** especially the slope of the enclosure which partly determines the type of motor to be used.

These factors determine the final properties of each roof.

For example, the more windy and snowy the location conditions are, the more the roof's structural elements will be reinforced, even to the extent of using thicker glass.

On the other hand, the characteristics of the installation location must be taken into account. In some cases, they are to be mounted on existing constructions in order to enclose

spaces. In other cases, such as when a new covered space is to be created, custom-made structures are designed.

It is therefore important to know how much the elements to be mounted weight, and how the anchorage points withstand them.

### Structures made to last.

Every structure manufactured by Airclos is studied and tested, choosing the right materials and profiles for each project.

This guarantees compliance with all resistance, bending and movement requirements of the standards observed, as well as with the quality criteria imposed by our products (which is sometimes more restrictive than the standards themselves).

The structures can be manufactured in steel and aluminium. Usually, the following types of structures are proposed:

- **Wall-mounted structure:** the most common. Usually built in aluminium. For large structures or spans between columns, steel is used.
- **Self-supporting structure:** they make it possible to create enclosed spaces anywhere. These structures require greater stiffness, so they are usually built in steel. The enclosure can be built in either single or double height.
- **Roof trusses and support elements:** retractable roofs require a surface to support the wall plate. Usually, this element is fixed on an existing partition wall. In cases in which a suitable surface to support the wall plate is not available, small structures are built in order to mount the roof.

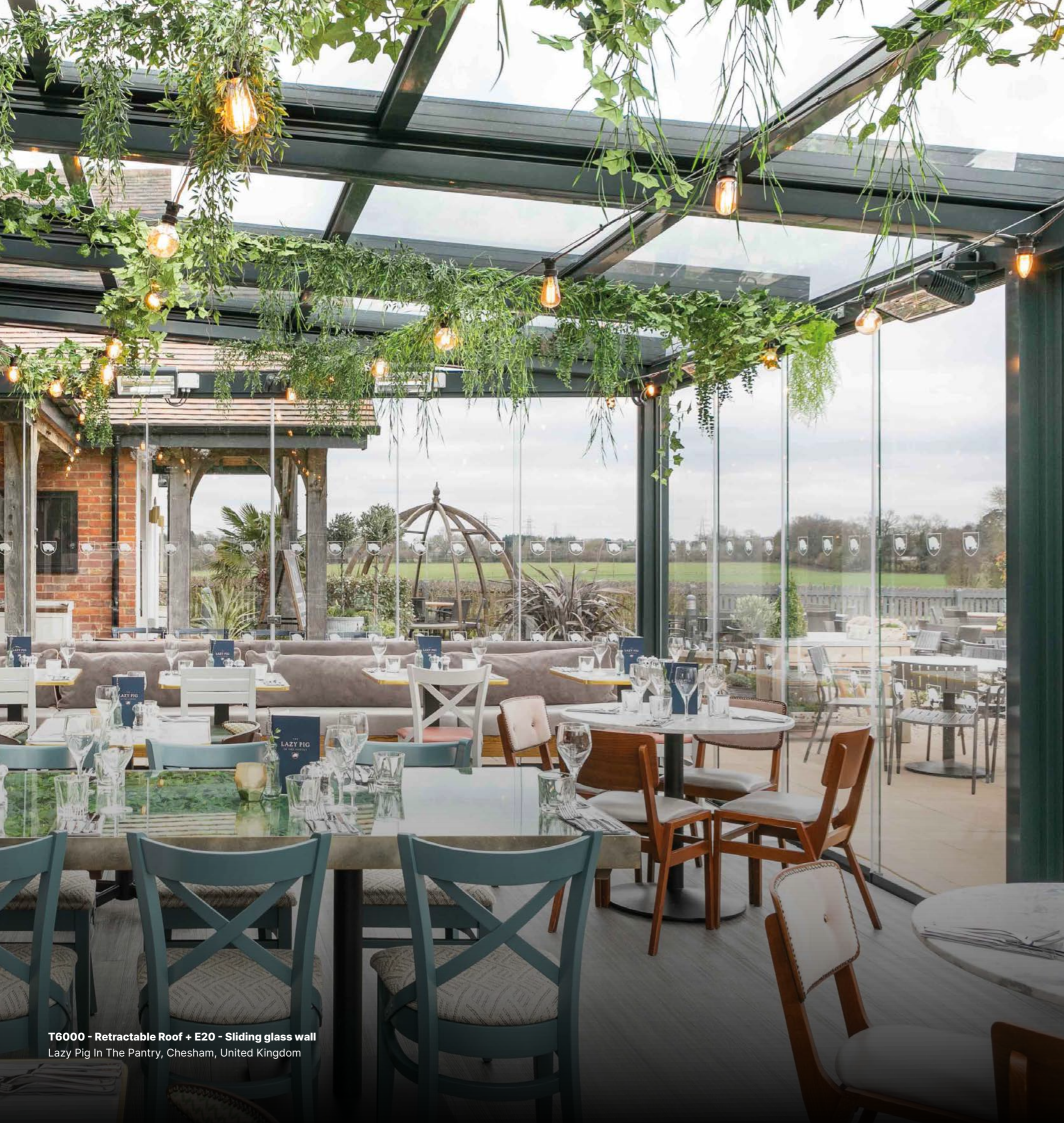

**Custom development.**  
Standard enclosures for patios and

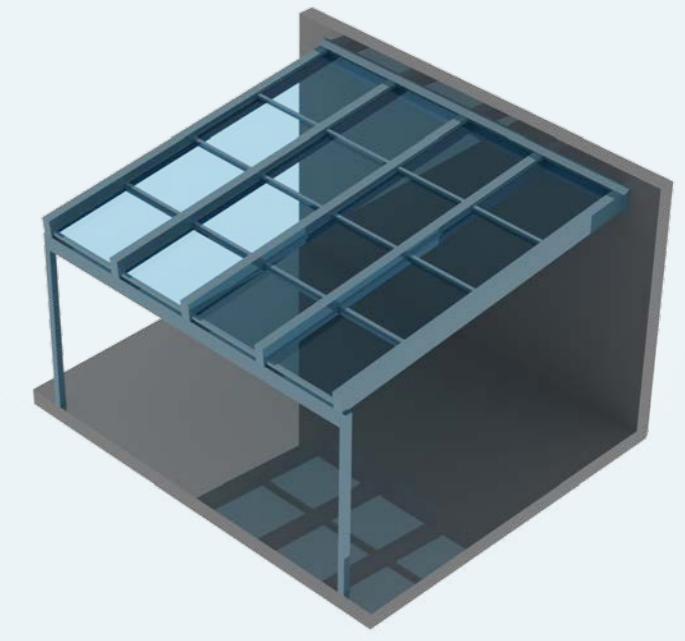

Standard opening - Closed position.



Standard opening - Open position.

T6000 - Retractable Roof + E20 - Sliding glass wall  
Lazy Pig In The Pantry, Chesham, United Kingdom

**Custom development.**  
Reverse opening enclosure.

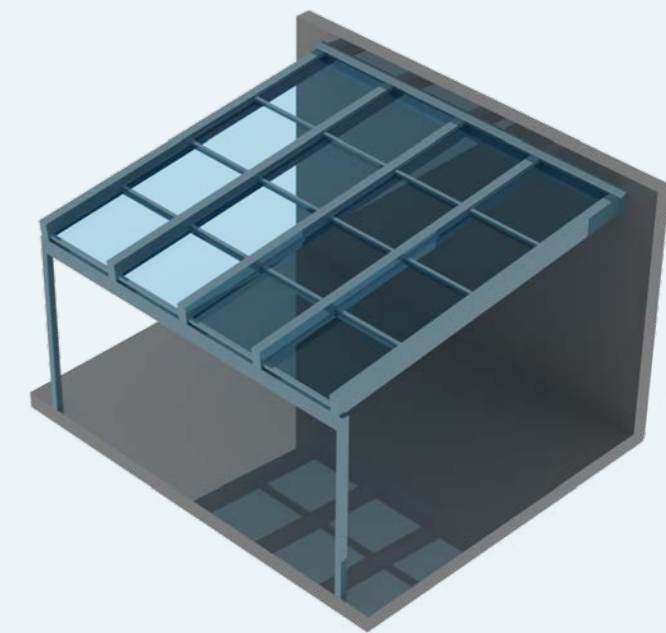

Reverse opening - Closed position.

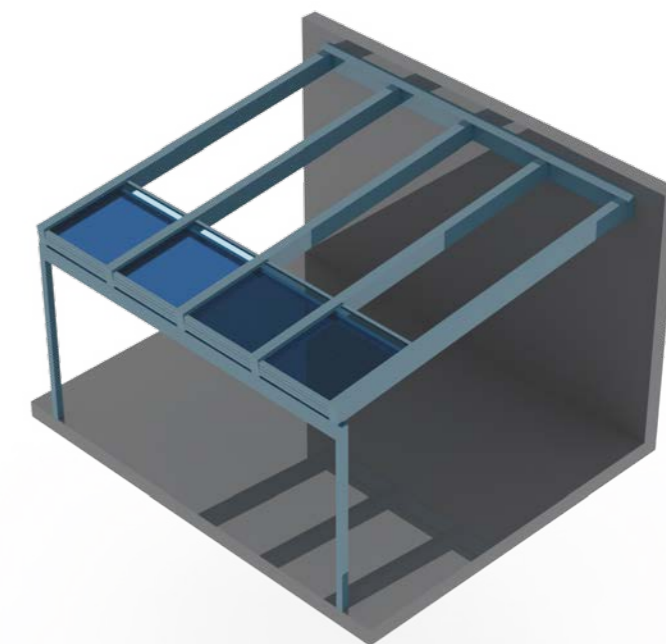

Reverse opening - Open position.



**T6000 - Retractable Roof**  
Private home, A Coruña, Spain



**Custom development.**  
Double slope enclosures.

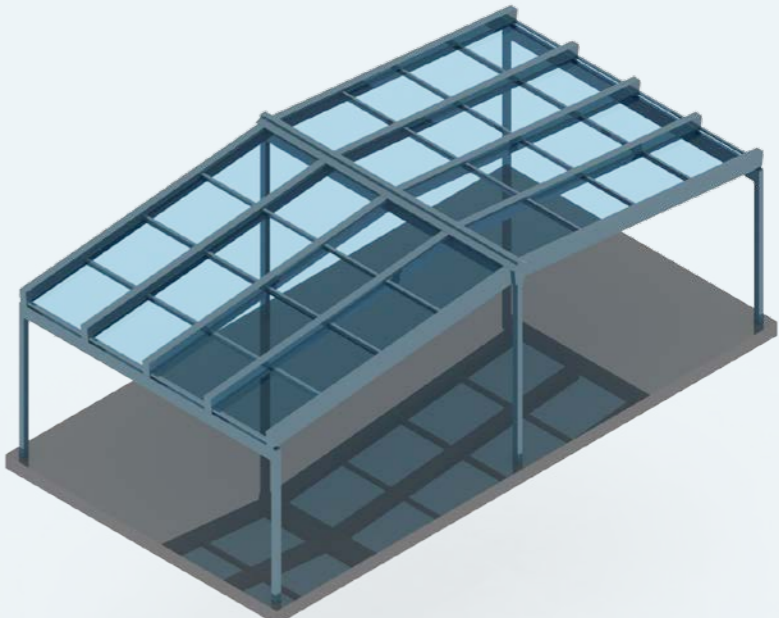

Double slope - Closed position.

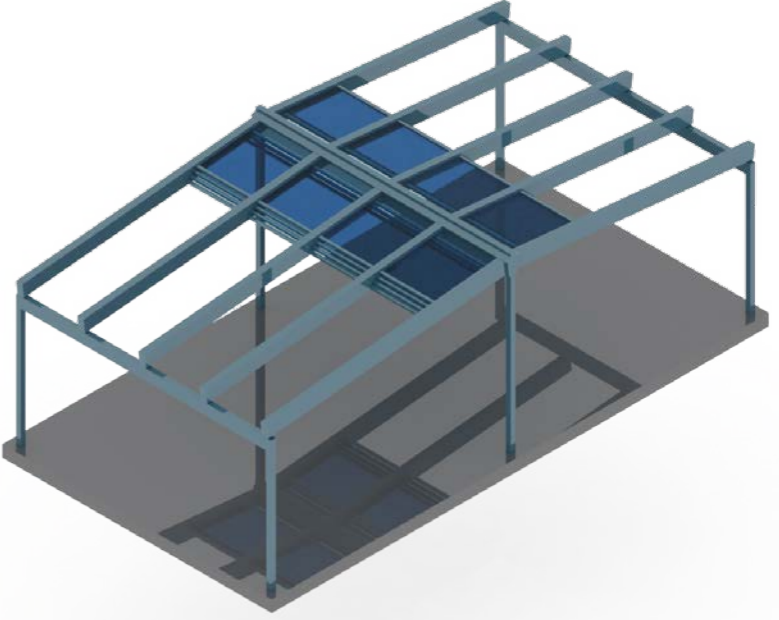

Double slope - Open position.

**T6000 - Retractable Roof + E45 - Stackable glass wall**  
Galp petrol station, Granada, Spain



**Custom development.**

Double slope with reverse opening.

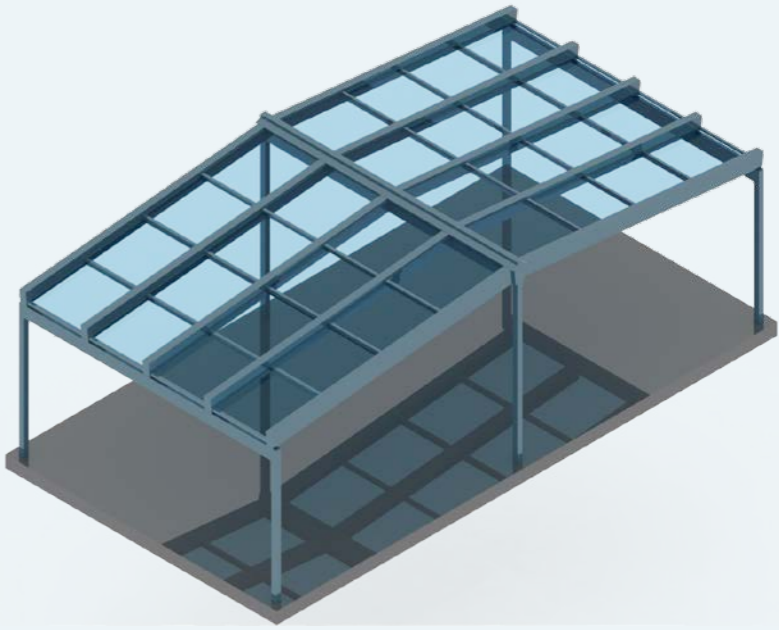

Double slope with reverse opening - Closed position.

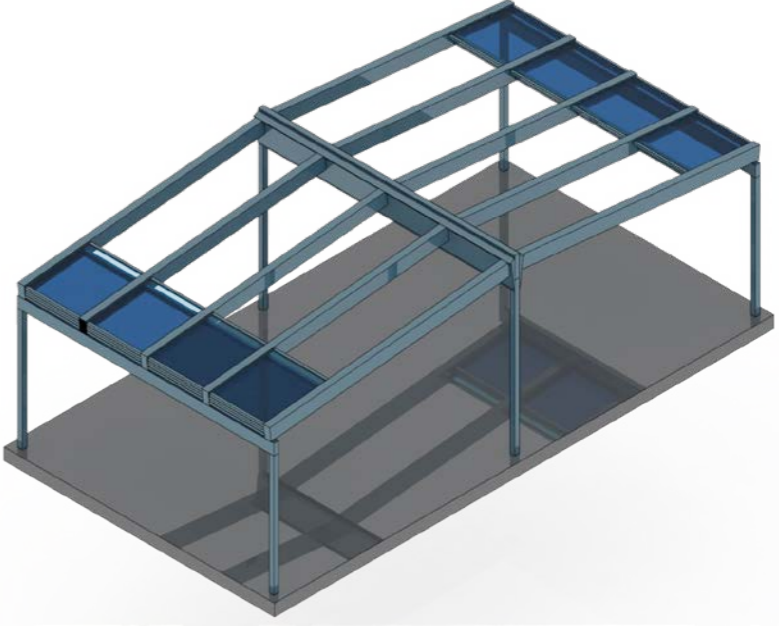

Double slope with reverse opening - Open position.

T6000 - Retractable Roof  
Opium, Dublin, Ireland

**Custom development.**  
Indoor patio enclosures.

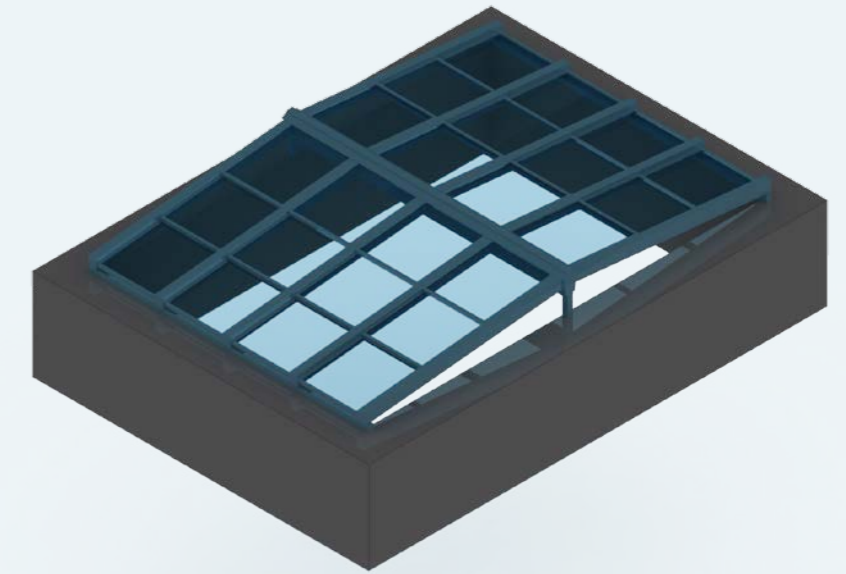

Inner patio - Closed position.

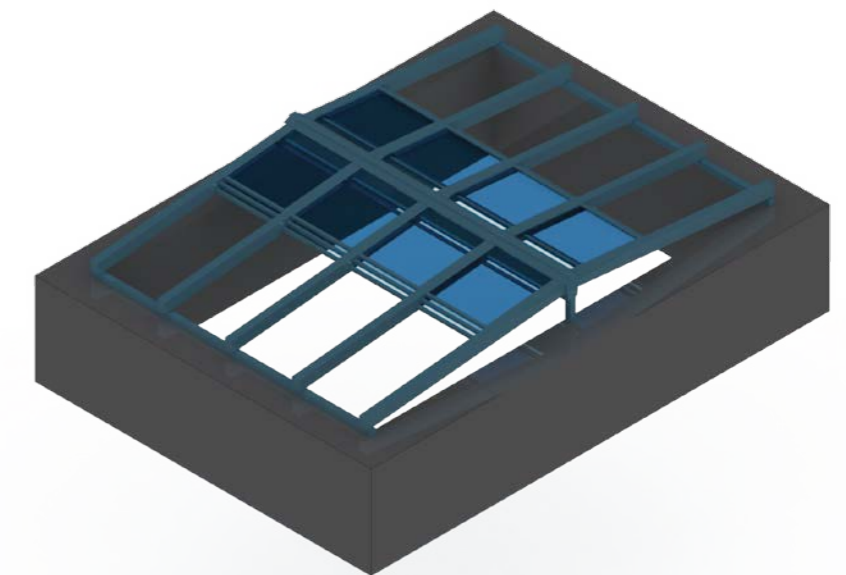

Inner patio - Open position.

**Custom development.**

Roof windows.

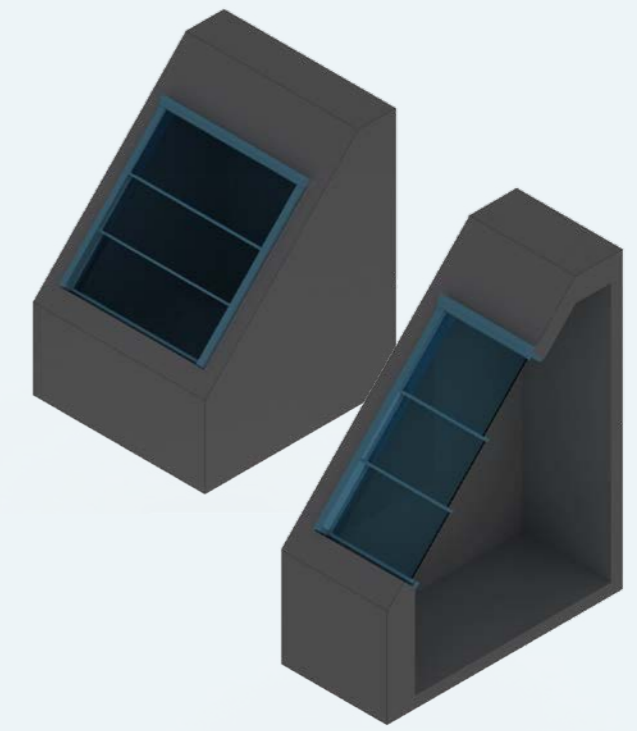

Roof window - Closed position.

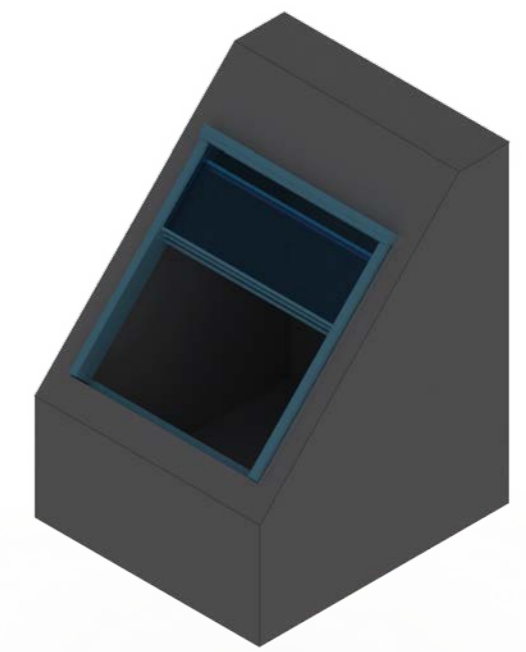

Roof window - Open position.

**T8000 - Retractable Roof**  
Julia's Park Residential complex , The Hague, The Netherlands

**Custom development.**  
Fully retractable sloped roofs.

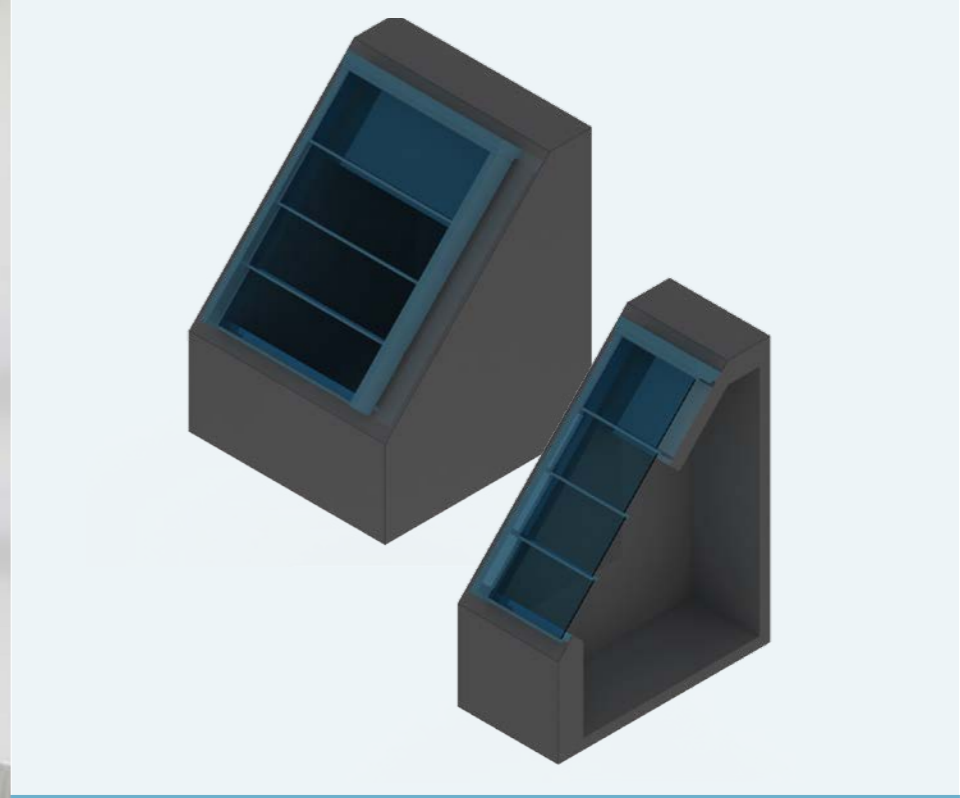

Sloped roofs - Closed position.

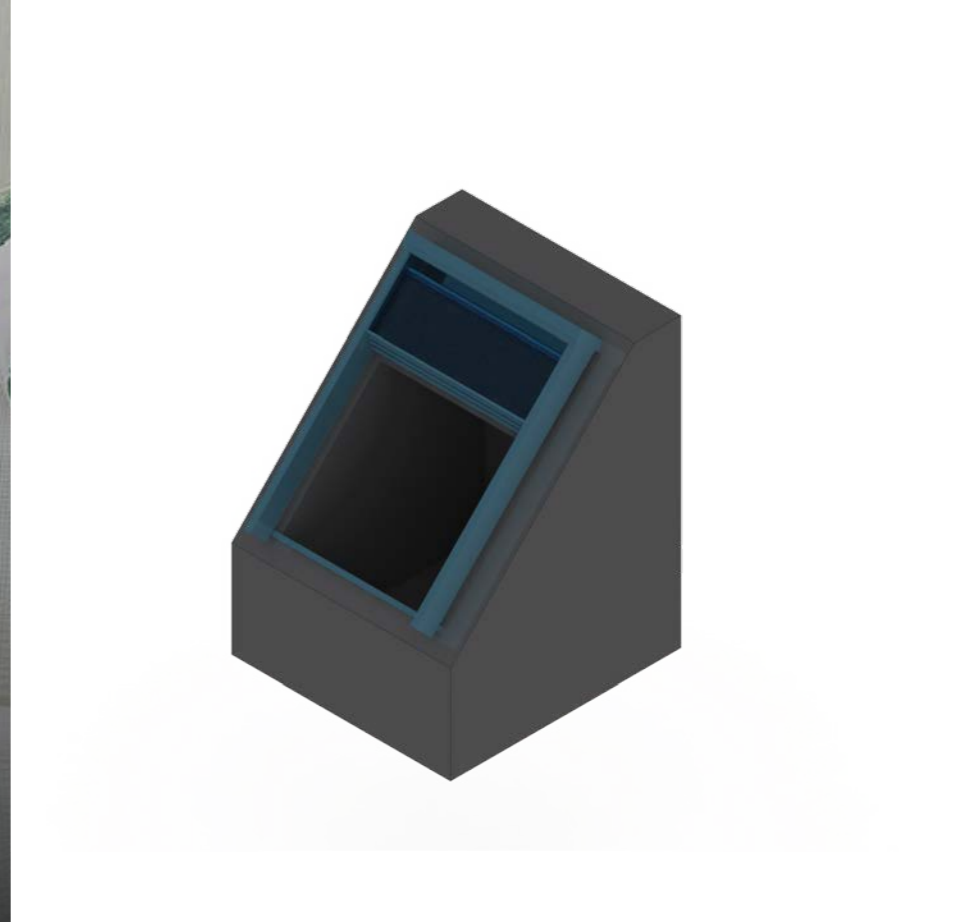

Sloped roofs - Open position.

**T8000 - Retractable Roof**  
Private home, Zarautz, Spain

**Custom development.**  
Module staircase enclosure.

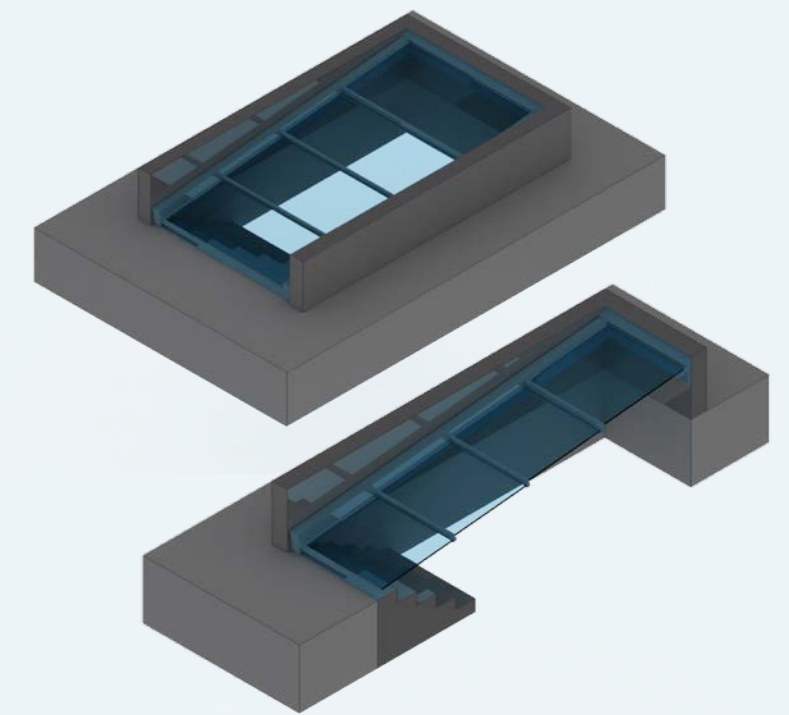

Staircase enclosure - Closed position.

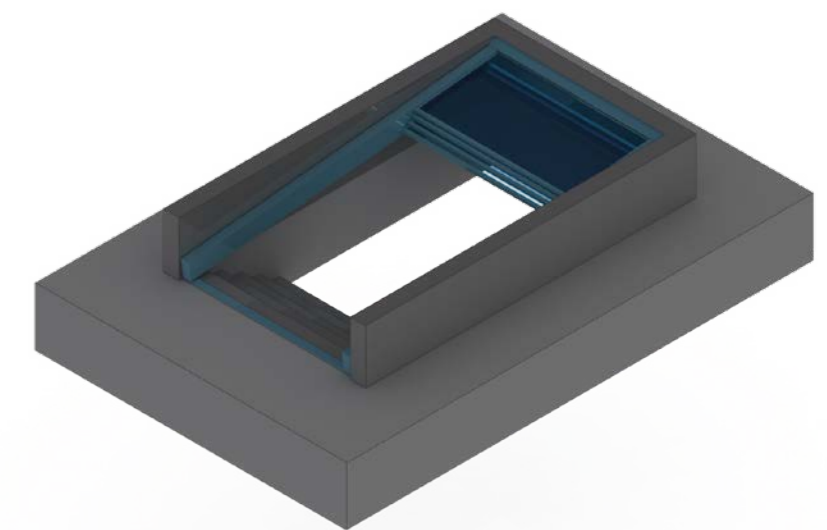

Staircase enclosure - Open position.

**Custom development.**

Double sloped roof.

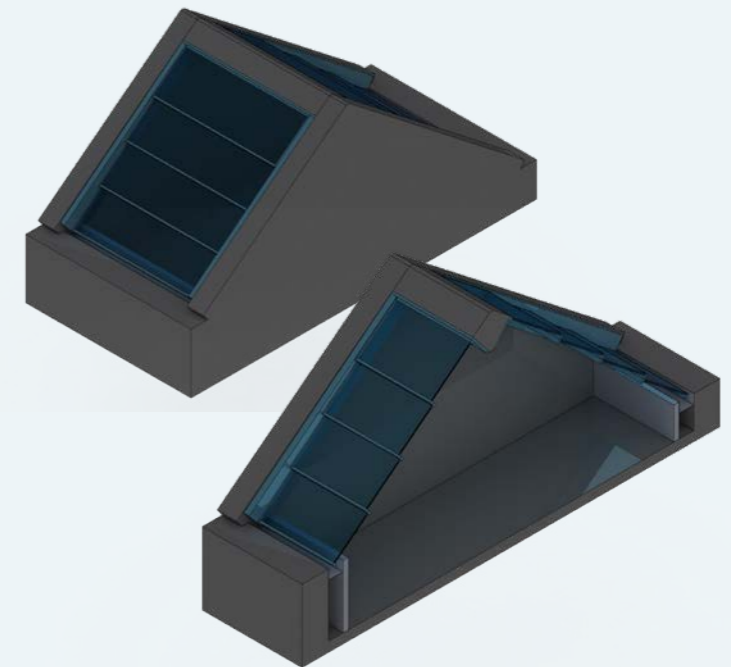

Double sloped roof - Closed position.

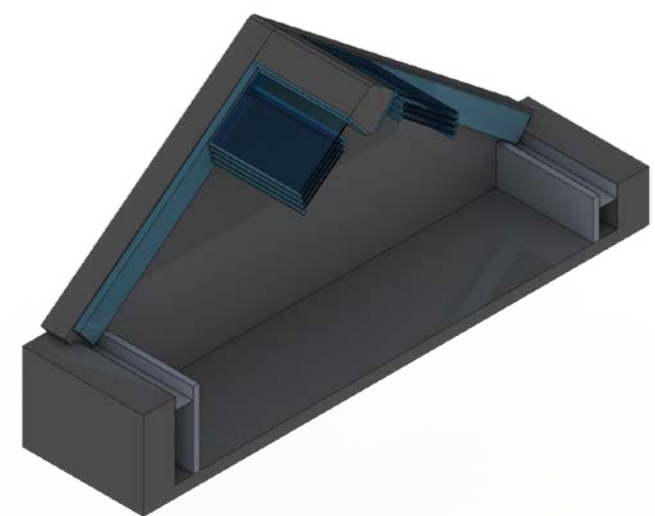

Double sloped roof - Open position.



**T8003 Retractable Roof**  
Private home under construction, Lire, France

**Custom development.**  
Retractable roof and fixed roof

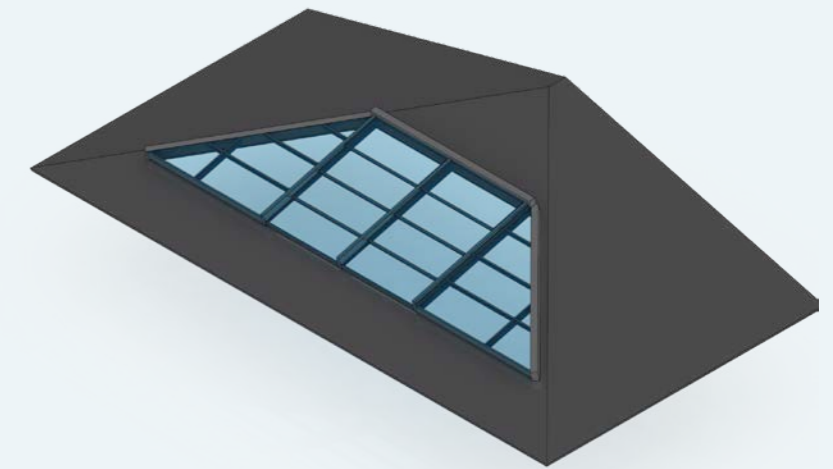

Retractable roof and fixed roof combination - Closed position.

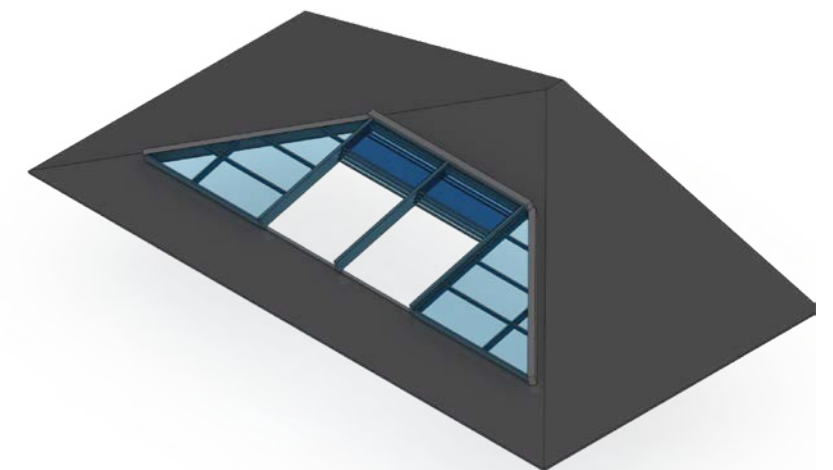

Retractable roof and fixed roof combination - Open position.



F105 - Fixed Roof  
Private home, The Hague, The Netherlands

**Custom development.**  
Special shapes.

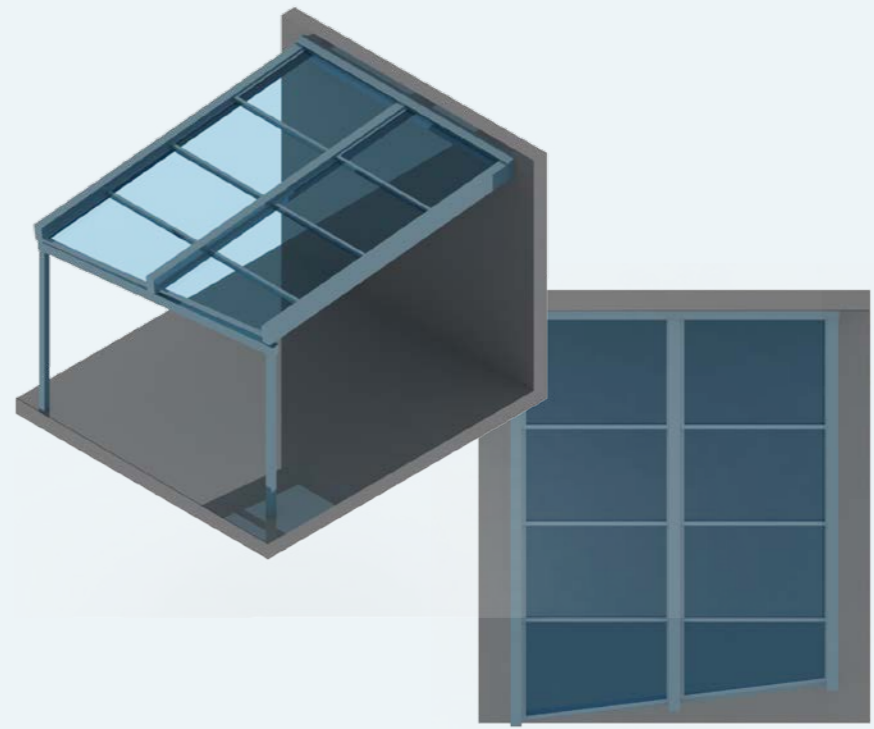

Special shape - Closed position.

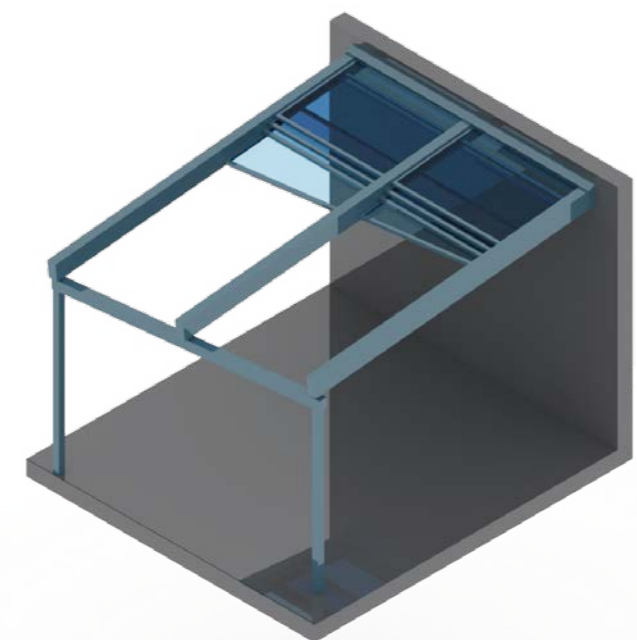

Special shape - Open position.



**Custom development.**  
Polygonal developments.

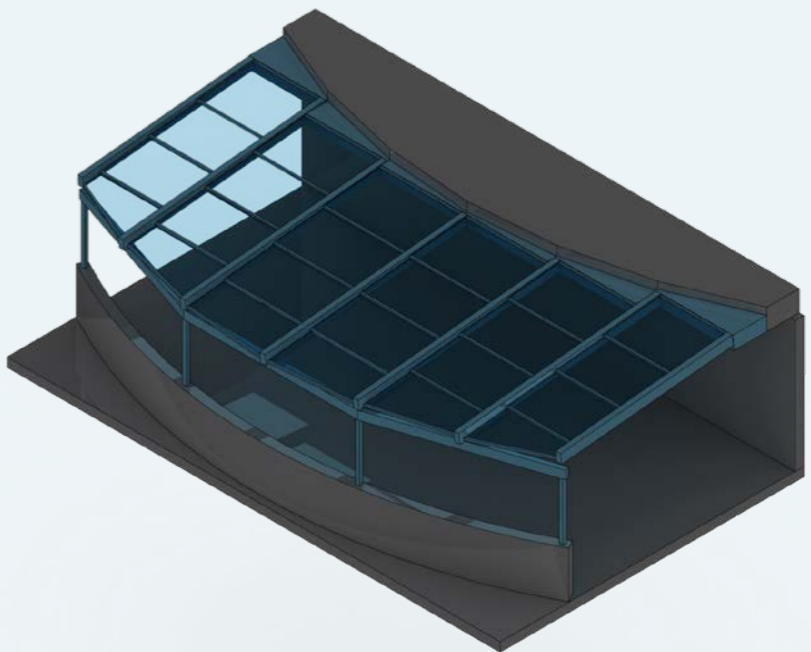

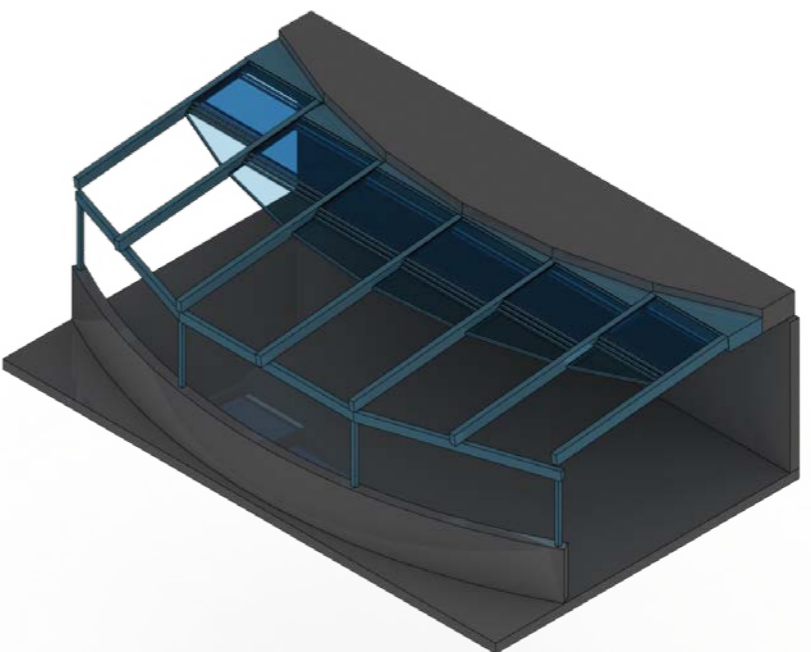

Polygonal development curve - Closed position.





Polygonal development curve - Open position.

## Advantages of Airclos' fixed and retractable roofs.

 **Efficient architecture and sustainable spaces.** Increases energy efficiency by reducing costs and environmental impact.

 **Increases business profitability and raises the value of their design.** We specialise in the hospitality industry, creating exclusive spaces to improve customer experience at any time of the year.

 **Up to 11.2-m projection and glass panels up to 3.6 m wide.** Let natural light flood into any room.

 **Automated opening of up to 90%.** Regain full contact with the outside in a matter of seconds.

 **Uw-value from 1.4 W/m<sup>2</sup>K.** The first retractable roofs on the market with True Thermal Break.

 **Ug-value from 0.5 W/m<sup>2</sup>K.** Triple glazing for the most demanding projects in terms of thermal and/or acoustic performance.

 **In-house manufactured fittings and accessories.** As a result, we have great control over the process and can offer an unbeatable after-sales service without intermediaries throughout the entire useful life of the product.

 **Offset glass.** A panel glazing system that creates a completely flat surface between the glass and the profiles, preventing water accumulation.

 **Traction by means of steel chain and cable.** Completely avoids elasticity and considerably increases the durability of the system.

 **Anti-derailment system.** Patented system that guarantees the correct sliding of the panels along the rails, avoiding derailment.

 **Cataphoresis treatment.** Cataphoresis treatment of the fixing supports and traction mechanisms to increase their durability.

 **Somfy motors.** Our retractable roofs are powered by tubular motors from Somfy, a leading brand in automation with over 40 years' experience worldwide.

 **Connected to the most advanced home automation.** Control the retractable roof from any smartphone or smart home and business device.

 **Emergency operation.** Built-in manual operation as emergency solution to possible electrical failures.

 **Rain, wind and sun sensors.** Enclosed areas are automatically protected when the desired levels of temperature, UV radiation, wind and rain are exceeded.

 **LED lighting.** LED lamps aesthetically integrated into the system itself and operated from the remote control.



T6000 - Retractable Roof  
Café en Seine, Dublin, Ireland

## Automation. Your home or business, always connected.

Enjoy an always-connected home or business with TaHoma®, the Somfy home automation box that allows you to control and centralise all your devices, including our motorised retractable roofs.

### TaHoma® by Somfy

TaHoma® allows you to control all Somfy motorised devices with RTS and IO technology.

Access the control panel remotely from any smart device (mobile phone, watch, tablet or computer) or any of the voice assistants available on the market (Google Home, Amazon Alexa and Apple HomeKit).

### Personalise your experience

TaHoma® is currently one of the most comprehensive platforms on the market.

Compatible with more than 250 Somfy products (entrance doors, windows, shutters, canopies, gates, garage doors, heating and lighting

systems, surveillance cameras, alarm systems, etc.), and a wide range of products from 20 other partner brands.

Not only will you be able to control your retractable roof remotely, you'll also be able to connect all the devices in your home or business and enjoy a unique experience.

Connect devices to activate them simultaneously, assign recurring tasks or schedule actions to perform them at specific times.

### Your data are safe

TaHoma® is certified by the independent organisation Syss, which guarantees the servers hosting and storing Somfy data meet the highest security standards, as well as the security of the web interface and the applications controlling the device.



## Glazing options.



Laminated glass



Tempered glass



Laminated tempered glass

### Laminated glass.

Laminated glass is a type of safety glass made from several glass sheets joint together by means of intermediary films of translucent plastic materials such as polyvinyl butyral (PVB) or ethylene-vinyl acetate (EVA).

Its most outstanding property is that, in case of fracture, the plastic film prevents glass fragments from breaking off, thus avoiding the risks of glass splinters.

### Tempered glass.

Tempered glass is a type of safety glass processed by thermal or chemical treatments to increase its strength when compared with normal glass. This is achieved by putting the outer surfaces into compression and the interior into tension.

Due to its special composition, when tempered glass is accidentally broken, it shatters into small granular pieces rather than splintering into large sharp shards. Granular pieces are less likely to cause injury.

### Laminated tempered glass.

Laminated-tempered glasses combine the qualities of both types of glass.

By combining these qualities, a type of glass that is highly resistant to impacts is created. Furthermore, in case of fracture, glass shards do not break off.



Double glazing



Triple glazing



Photovoltaic insulating glass

### Double glazing.

The insulating glass consists of two glass sheets separated by an air space that prevents glass to glass contact.

The inner space is usually filled with dry air or another inert gas (argon gas, xenon, krypton, etc.), but it is also possible to create a vacuum effect.

The most remarkable aspect is that it offers the possibility of designing customised glass panels, which can also incorporate thermal, acoustic and safety insulation.

### Triple glazing.

Triple glazing or double air space windows are designed under the same premises as with insulating glass, except that by adding a space and an additional glass sheet, its performance is improved on several levels (thermal insulation is improved, and energy consumption and environmental impact are reduced).

In this case, the main objective of using triple glazing is reducing the Ug-value of the glass, thus improving its insulation (the Ug-value measures the temperature exchange between the inside and outside of a room. The lower the Ug-value, the lower the transmission).

### Photovoltaic insulating glass.

Added to the advantages of insulating glass, transparent photovoltaic glass turns insolation into power.

The glass panels are also thermally treated to provide high levels of thermal and acoustic insulation. Insulating glass also stands out for its total transparency, which allows sunlight to penetrate the rooms unhindered.

Insulating glass can thus contribute to creating more efficient buildings.

## Property comparison between series.



	<b>T6000</b>	<b>T6000V</b>	<b>T8000</b>	<b>T8003</b>	<b>T8000 ER</b>	<b>T7000 RPT</b>	<b>F105 RPT</b>
<b>Material</b>	Aluminium	Aluminium	Aluminium	Aluminium	Aluminium	Aluminium	Aluminium
<b>Profile finishes</b>	RAL · Anodised · Wood	RAL · Anodised · Wood	RAL · Anodised · Wood	RAL · Anodised · Wood	RAL · Anodised · Wood	RAL · Anodised · Wood	RAL · Anodised · Wood
<b>System</b>	Retractable, motorised	Retractable, motorised	Retractable, motorised	Retractable, motorised	Retractable, motorised	Retractable, motorised	Fixed
<b>Multi-channel control</b>	Yes	Yes	Yes	Yes	Yes	Yes	–
<b>Max. panel width with glass</b>	2,200 mm	1,500 mm	3,600 mm	3,600 mm	4,000 mm	2,200 mm	900 mm
<b>Maximum panel width with sandwich panel</b>	2,300 mm	–	–	–	–	–	–
<b>Maximum polycarbonate panel width</b>	2,300 mm	–	–	–	–	–	–
<b>Maximum projection without intermediary pillars</b>	8,500 mm	8,500 mm	6,500 mm	6,500 mm	6,500 mm	6,500 mm	7,000 mm
<b>Opening</b>	66, 75, 80, 83, 86, 87%	66, 75, 80, 83, 86, 87%	66, 75, 80%	66, 75, 80%	50, 66, 75, 80, 83 %	66, 75, 80%	–
<b>Slope</b>	Standard: 10% 8 - 100 (45°)	Standard: 10% 8 - 100 (45°)	Standard: 10% 8 - 100 (45°)	Standard: 10% 8 - 100 (45°)	Standard: 10% 8 - 100 (45°)	Standard: 10% 8 - 100 (45°)	Standard: 10% 8 - 100 (45°)
<b>Number of panels per module</b>	2 - 8	2 - 8	3 - 5	3 - 5	3 - 5	3 - 5	–
<b>Uw-value</b>	3.0 W/m <sup>2</sup> K	6.05 W/m <sup>2</sup> K	2.76 W/m <sup>2</sup> K	2.4 W/m <sup>2</sup> K	2.8 W/m <sup>2</sup> K	1,4 W/m <sup>2</sup> K	1.2 W/m <sup>2</sup> K
<b>Laminated glass</b>	4+4 mm	6+6 / 6+6T	–	–	–	–	–
<b>Double glazing</b>	28 mm	–	28 mm	–	36 mm	–	28 mm
<b>Triple glazing</b>	–	–	–	50 mm	–	58 mm	–
<b>Polycarbonate</b>	16, 20, 25 mm	–	–	–	–	–	–
<b>Aluminium panel</b>	16, 20, 25 mm	–	–	–	–	–	–

Please enquire for further options not specified in the table.

## Other Airclos products.

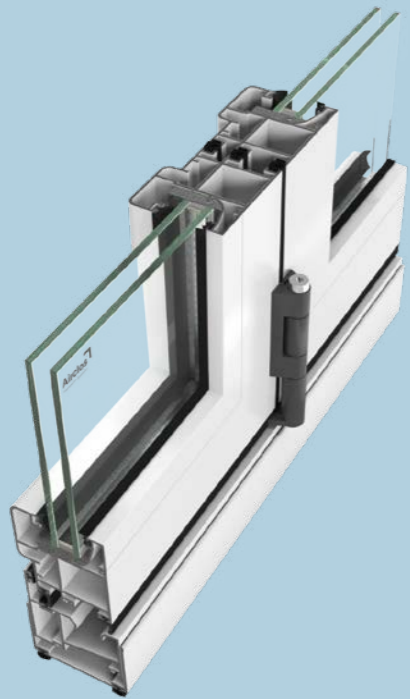

Bi-fold doors

### Bi-fold doors.

Aluminium bi-fold doors are, together with fixed and retractable roof systems, the brand's most traditional products.

Our range of bi-fold doors is the widest on the market, with a series specially designed to meet the needs of our customers.

Among the different options available, we would like to highlight our high insulation TB series (Uw values from 1.3 W/m<sup>2</sup>K), as well as our minimalist and oversized series in which the glass becomes the main protagonist.

It is especially noteworthy to mention that the system can be customised to suit each project. Features such as the opening, the number and combination of panels, the colour of the profiles, the type of locking system, etc. can be customised.

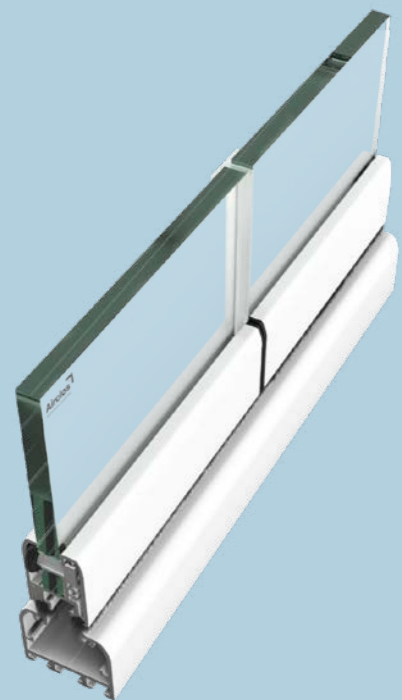

Glass walls

### Glass walls.

Glass wall enclosures are glazing systems without vertical profiles that help to protect rooms and terraces fully respecting the views and without altering at all the architectural style of the building's facade.

Among its profiles, they have totally transparent vertical gaskets which help to protect the space with no impact on the panoramic view.

Enjoy your terrace beyond the summer season. Thanks to the installation of glass walls, the space will be protected from rain, wind and dust.

Additionally, the installation of glass glass will considerably increase the overall comfort of the room, reducing air, dust and noise from the outside.

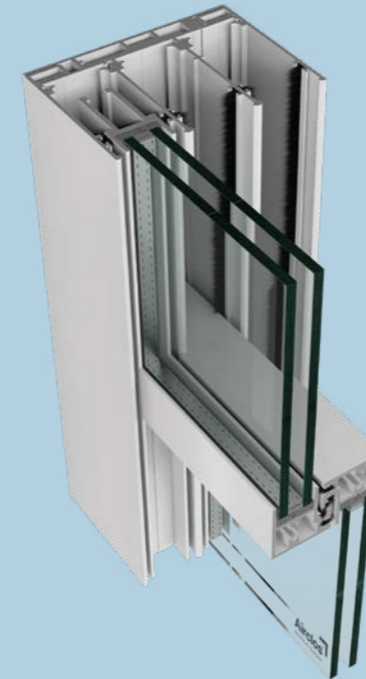

Vertical sliding panel

### Vertical sliding window.

The Airclos vertical sliding window system is a sash window consisting of large glass panels.

Perfect for enclosing any room while taking up minimum space.

Thanks to its large size, up to 4 × 4 m, it is possible to achieve great panoramic views without losing insulation and tightness.

Furthermore, this innovative system brings a breakthrough to the market, as it can be opened from the bottom as well as from the top.

When opened from the bottom, the sash window system is kept at an optimum safety height, acting as a railing. When opened from the top, the panels are suspended from above, allowing passage under the system.

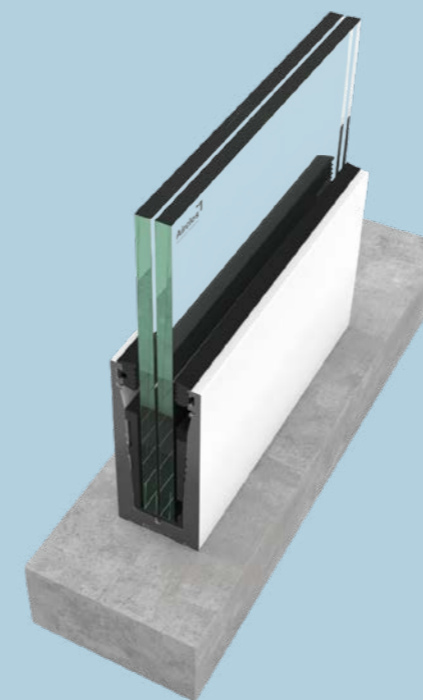

Glass railing

### Glass railing.

A glass railing system that stands out for its great transparency. The lower profile takes up a minimum of visible space and can be installed on the floor or recessed.

The tempered safety glass and other elements, such as a built-in drainage system, make the system more resistant, perfect for both indoor and outdoor use.

On the other hand, the wide variety of profiles developed by Airclos admits glass railing installation in very diverse conditions without compromising the system safety.

Therefore, it is the best solution for complex projects because it can be installed even by side mounting.

Large international projects.



Refer to our website for more interesting details about our projects: [www.airclos.com](http://www.airclos.com)

**Airclos**<sup>®</sup>  
Aluminium Systems

**Alghussun**  
GLASS LLC

Office No : 1103 , Le Solarium Building  
Nad Hessa Street , Silicon Oasis - Dubai

Tel: +971 4 3332267

Email: [info@alghussunglass.com](mailto:info@alghussunglass.com)

[www.alghussunglass.com](http://www.alghussunglass.com)